

Enterprise PLM- A Global Competitive and Compliance Imperative

David G. Sherburne

Executive IT Director- Carestream Health Incorporated
Technology Consultant and Evangelist
Avid Photographer

david.g.sherburne@carestream.com

me@davidgsherburne.com

<https://www.linkedin.com/in/davidsherburne>

www.queptography.com

<https://www.twitter.com/dgsherburne>



Carestream

An independent company with a proven track record and \$2+ billion in revenue

A world leader in:

- Medical imaging ... digital imaging solutions and traditional film
- Healthcare information solutions
- Dental ... media, digital imaging solutions and practice management software
- Non-destructive testing.. media, imaging solutions



“ Globalization has added complexity to knowledge workers operational environments robbing their time to innovate ”

“ Unmanaged application and process proliferation is an Achilles Heel (weakness) for a regulated company”

“ IoT data will further complicate business, disrupt markets and dramatically change time to market expectations for releasing innovative data enhanced services”

Challenges- Globalization

Globalization was enabled by internet connectivity

- leverage world wide talent
- balances the cost structure
- allows presence in emerging markets

What to understand and manage

- Collaboration becomes more time consuming robbing innovation cycles
- Complexity in the organization increases as work groups decentralize
- Productivity can be negative if process, tools, and master data are not given proper consideration
- Regulatory risk footprint increases as business process and tool diversification occurs

“Business processes enabled IT applications are the circulatory system for your innovation engine, when clogged life moves slower and in a much more limited fashion, a silent killer in a data enabled world”



Challenges- Application and Process Proliferation

Mergers & Acquisitions and IT Neglect can lead to System Proliferation

- Organic and inorganic growth
- New market opportunities
- IT Cost focus not a strategic focus



What to understand and manage- IT is no longer just a cost center in today's world

- Geographic and company proximity and culture will impact the willingness to change, **discuss IT!**
- Purchased companies have existing IT and business infrastructures, **harmonize IT!**
- Change is difficult, a natural resistance to harmonization, **lead IT!**
- Process and IT proliferation will occur if neglected, **manage IT!**

“Customers do not buy your engineering change control process or PLM system, they buy your products and innovation content that is maintained and controlled within PLM”

Challenges- Compliance

Regulations and compliance is our way of life, but compliance presents opportunities

Internal and External Audit findings

Universal Device Identification (UDI) and Registration

China FDA

FDA focus on sustained quality of outcomes vs pure compliance



What to understand and manage

Internal Audits are a good source for assessment of your current risk foot print and process opportunities

Design of a new process and tool set to meet regulations can create an opportunity to harmonize

Verification and Validation of computer systems takes time, effort and attention, harmonization saves time

“PLM is a critical enterprise platform that must evolve to support a quality mindset of continuous business improvement, reduction of compliance risks and prepare the company for a data enabled fast paced future”

FDA is taking a new approach

- In recent years, a growing number of patients have suffered from adverse events due to medical devices. To better understand the reasons for these lapses in quality and safety, we conducted interviews with medical device industry thought leaders and FDA leadership and in parallel analyzed FDA adverse event reports and recall data.
- Our efforts revealed that there are systemic gaps within the medical device industry's quality approach that result in these issues. Attempts to improve quality are hindered by challenges within the industry as well as specific aspects of the Agency's regulatory approach. Moving toward greater visibility into device quality and properly aligning FDA's regulatory approach will be important to catalyzing industry movement towards improved device quality. ***Investment by FDA now in a holistic quality infrastructure will support a next generation of medical devices that are as safe and well made as they are innovative.***

“Increasing complexity of medical devices and usage environments is straining the current quality system infrastructure. Companies report that they have not systematically upgraded their quality infrastructure due to the unclear economics and concerns about regulation. “

Understanding Barriers to Medical
Device Quality



Oct. 31, 2011

Accelerating Change – 3rd Wave of IT is birthing a 4th Wave of Industry Productivity

Here comes - Industry 4.0

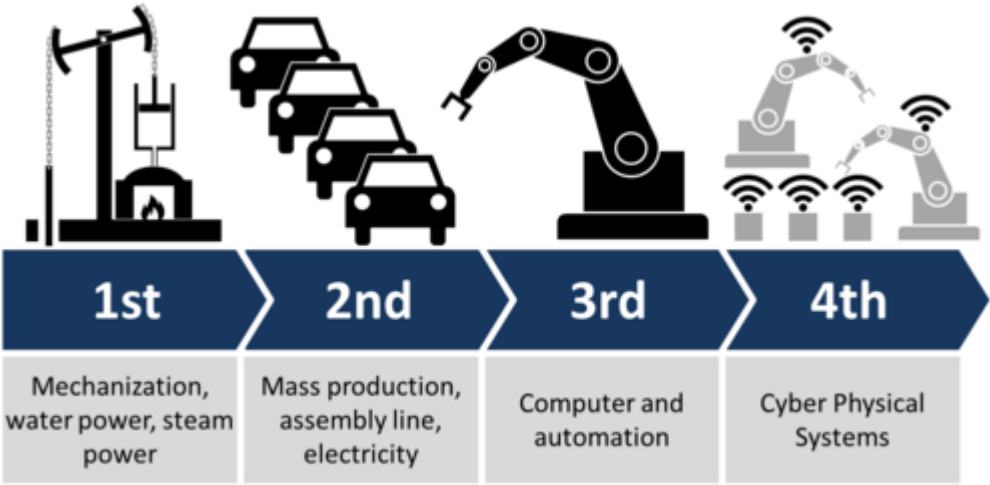

\$30b+ investments

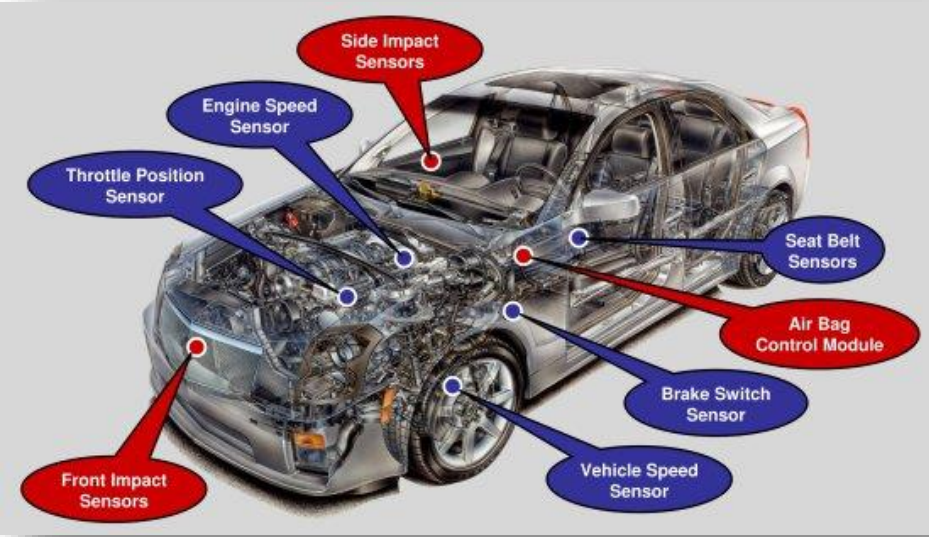

- Powerful Connected Devices
- Connectivity - Internet
- Cloud Computing Infrastructure
- Ubiquitous Sensing
- Data Sharing, Social Networking



AN EXPLOSION IN CONNECTED DEVICES

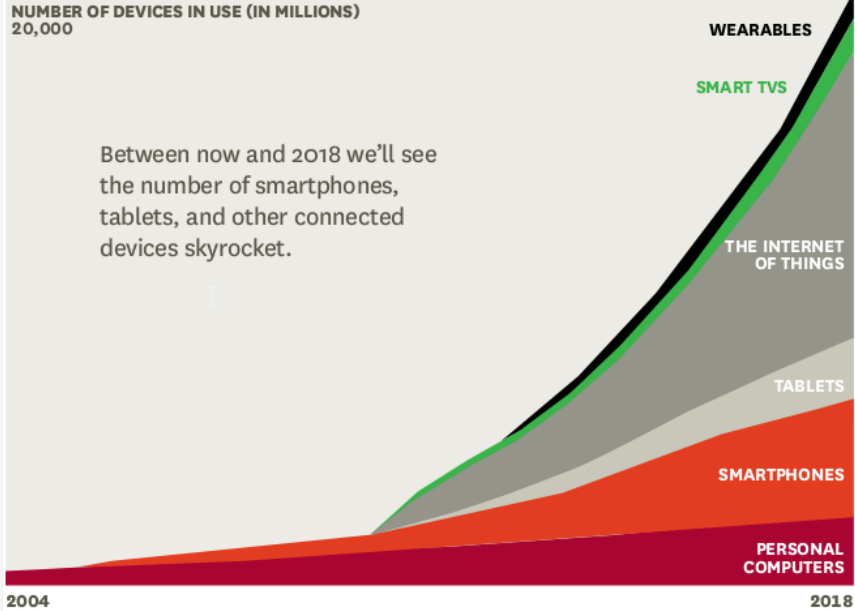

SOURCE: BI INTELLIGENCE ESTIMATES BASED ON DATA FROM GARTNER RESEARCH, IDC, STRATEGY ANALYTICS, MACHINA RESEARCH, AND OTHERS

IoT DATA IS DISRUPTING MARKETS ALREADY

Digital Enablement is here

“Over the next five years many business components will be digitized to enable a new range of products, services, and business models.” -

HBR Nov 2014

New Devices

NEST- will not only play in the \$3 billion global thermostat sector;

NEST will shape the \$6 trillion energy sector.

- HBR Nov 2014

New Business Models - CEO Travis Kalanick on Uber's \$40B Valuation

The taxi market in San Francisco is about \$140 million per year Uber's SF revenues at \$500 million per year. (That's over 3x!)

Uber and automated cars are reshaping the world wide automotive industry

So what does this all really mean ?

“Tightly managing your information from cradle to grave is table stakes to maintain effectiveness and compliance in a digitally connected world”

”The ability to “hyper innovate” services around data and rapidly evolve hardware through software will become the competitive advantage as data shapes consumption patterns and market expectations”

“Enterprise PLM is core to compliance, process automation, flow of information and master data management across the lifecycle”

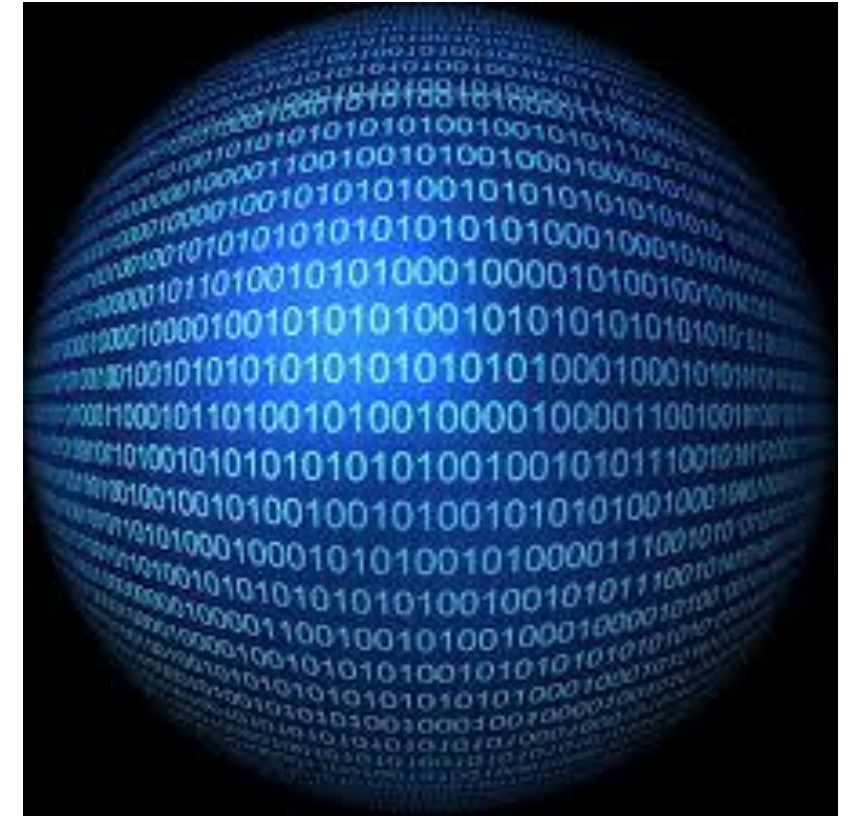

Baselines - Integrated Lifecycle Data Management ILM (PLM+)

Quality System Framework

PLM

MES/SLM

QMS

PCM

IoT

Concept

Design

Release

Maintain

Discontinue

End Life

Design Baseline- DHF

Product Configuration Baseline- DMR

As Built Production Baseline-DHR

As Serviced Baseline- DHR Extended

Sales Information Baseline- Product Content Management

IoT Data Streams

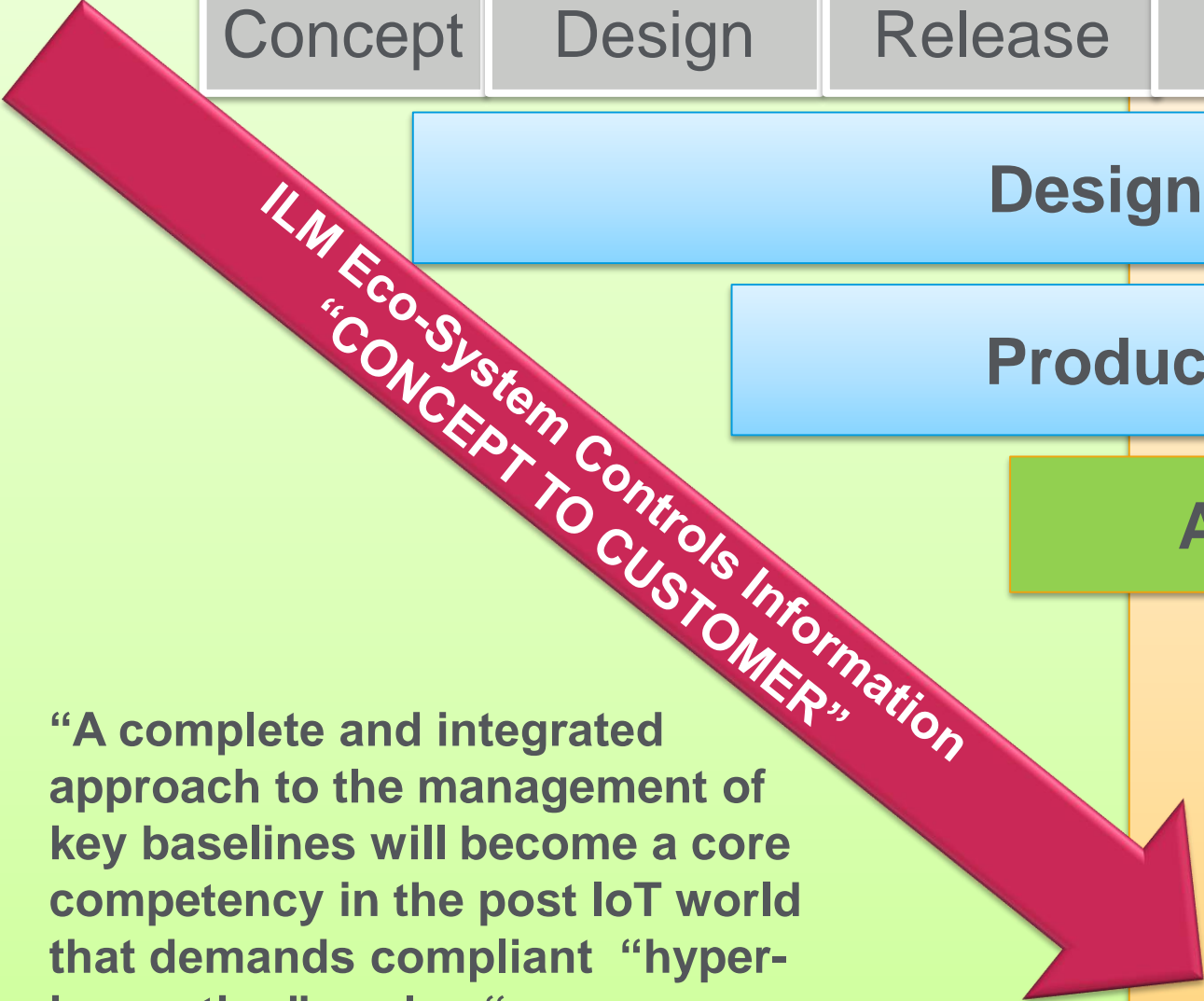

“A complete and integrated approach to the management of key baselines will become a core competency in the post IoT world that demands compliant “hyper-innovation” cycles “

Process Based Solutions Architecture View of the Quality System

Consolidated macro process view is critical to communications and strategic planning

Helps business to visualize IT solution architecture

Process automation, data flow and IT system harmonization are enabled through clear communications

Provides a basis for planning over a long period of time

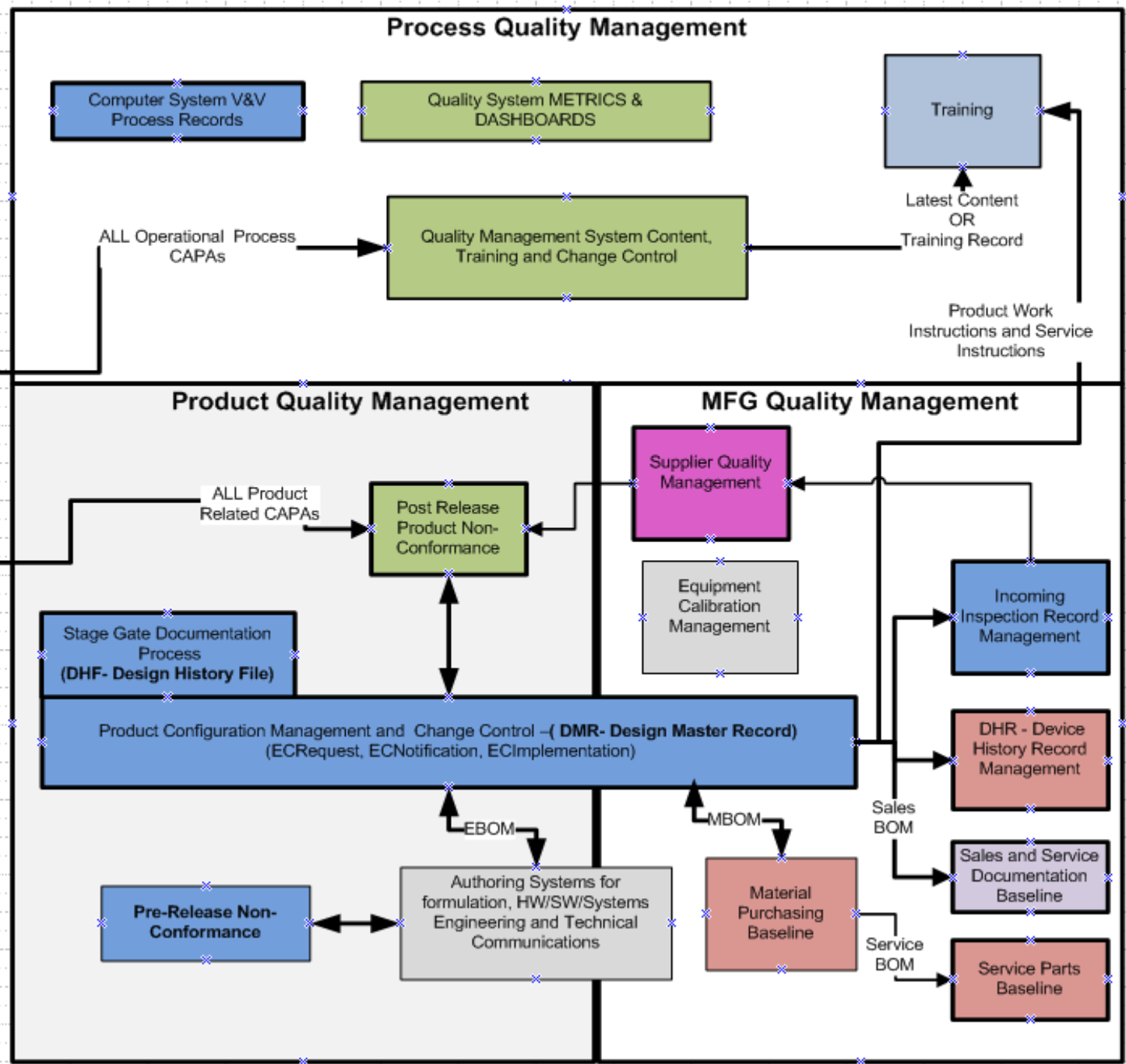
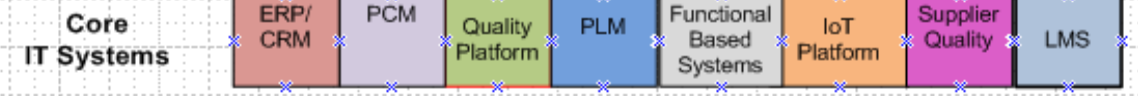
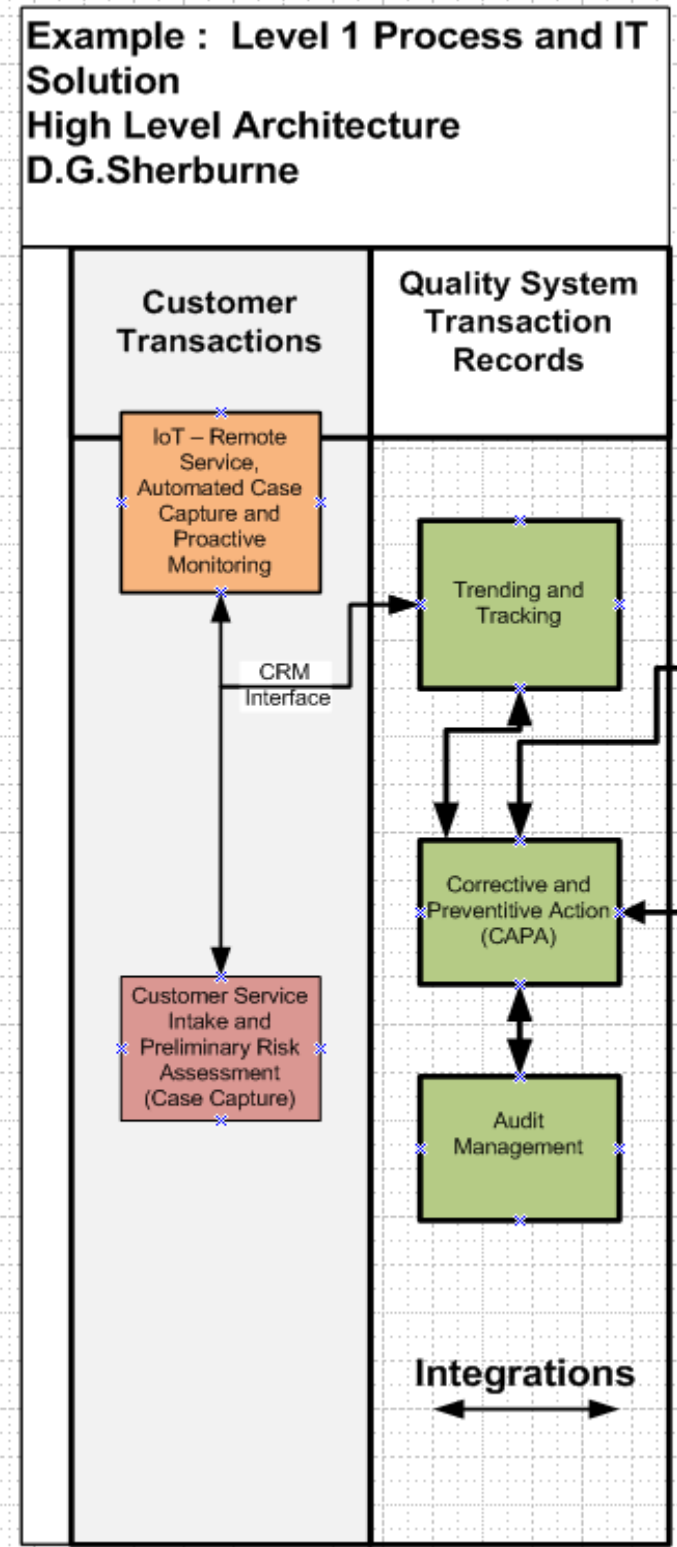

SOURCE: David G. Sherburne
 March 2016 All Rights Reserved

Visualize an Integrated Lifecycle Management Ecosystem

Goal: Fast and efficient master data flow end to end across IT systems

Consolidate **ALL** product related (DHF, DMR) baseline data in the Enterprise PLM System Use a PLM core to automate processes and flow data across the product lifecycle

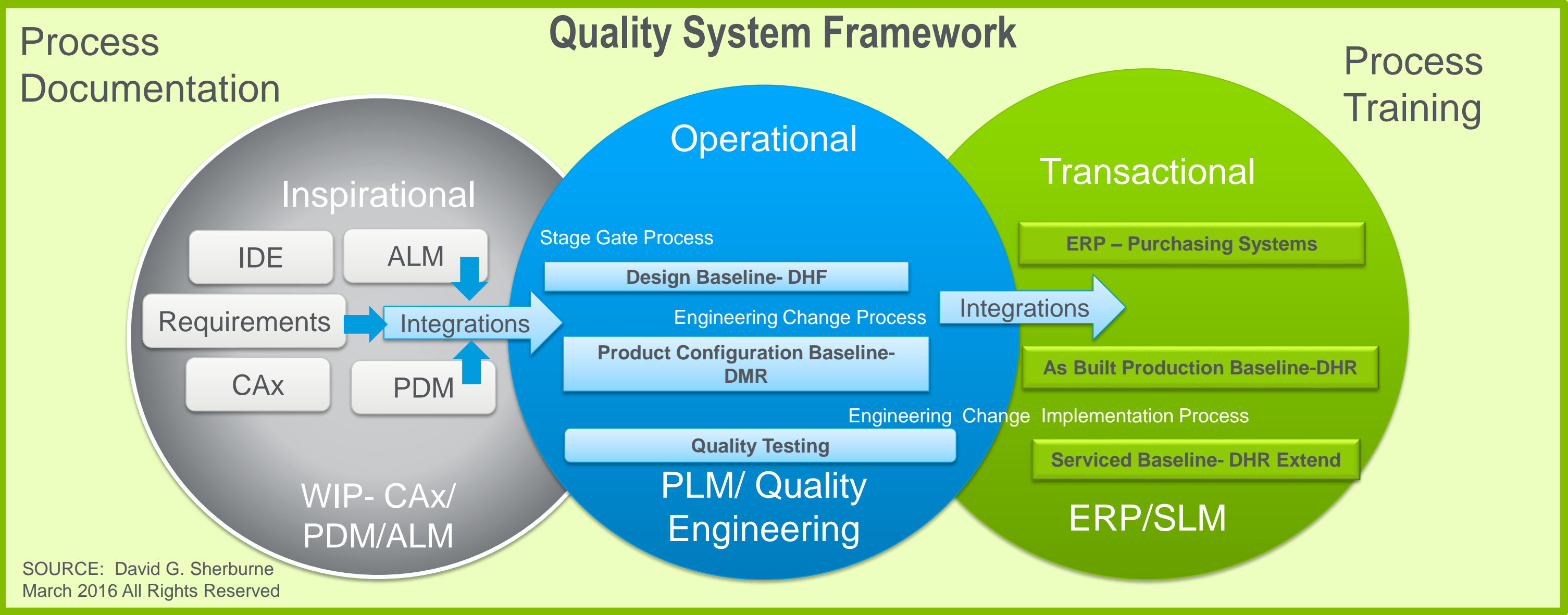

SOURCE: David G. Sherburne
March 2016 All Rights Reserved

DEFINE and CONSOLIDATE the Baseline of Configuration Items

Document Families

Example- Product Configuration Baseline- Design Master Record (DMR)

Look in Engineering Systems

- Engineering Change
- Bill Of Materials
- Composition
 - Drawings
 - Specs
 - Formulation
- Design Information
 - SW/HW/SYS

Look in Manufacturing Systems

- Process Specifications
 - equipment
 - methods
 - environment
- Device Identification
 - Submission
 - Labeling
 - Track
- Quality Assurance Records
 - Inspection
 - Testing
- Work Instructions
 - Methods
 - Training
- Non-conformance
 - Process
 - Parts

Look in Documentation Systems

- Product Labeling
 - Specs
 - Process
- Technical Pubs
 - Install
 - Service
 - Maintain

Configuration Item Proliferation

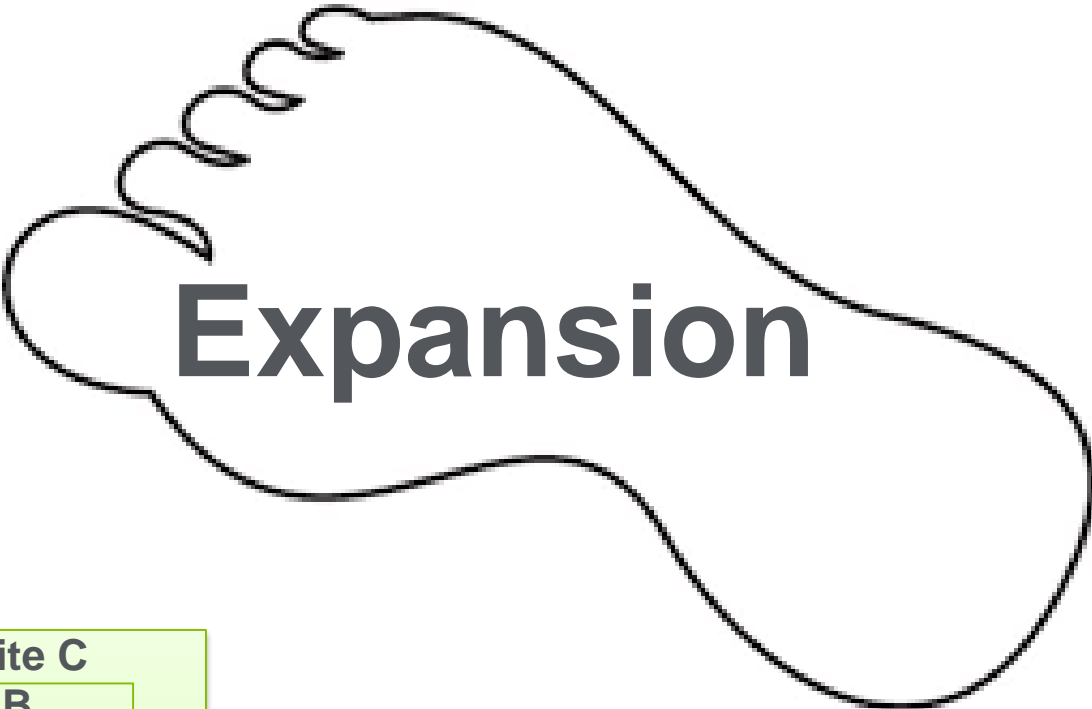
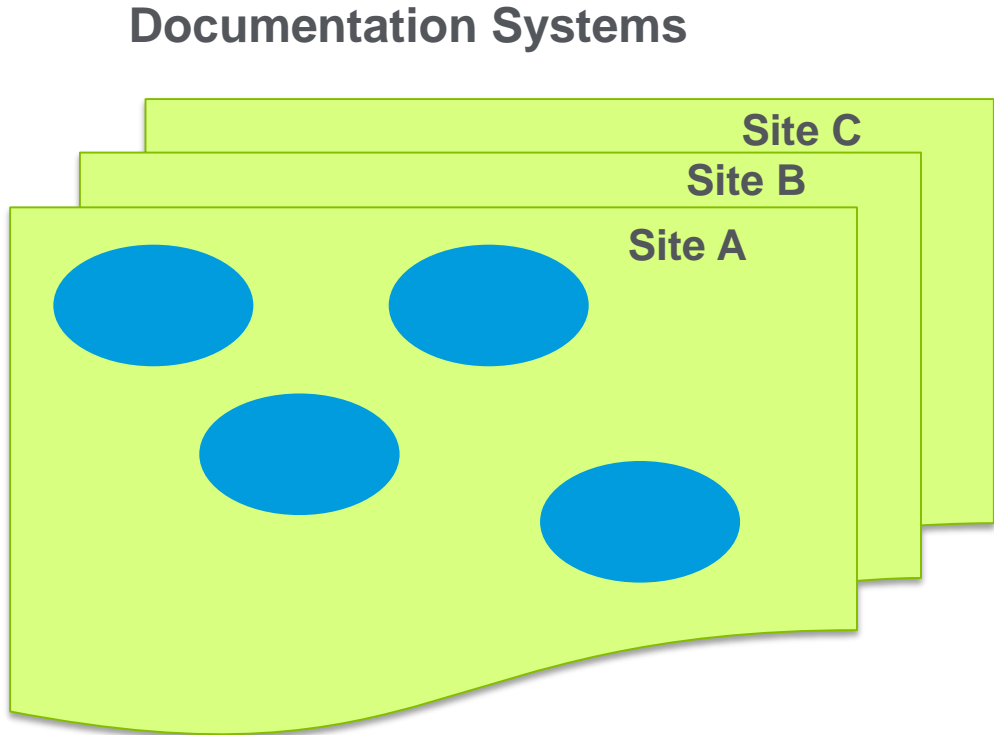
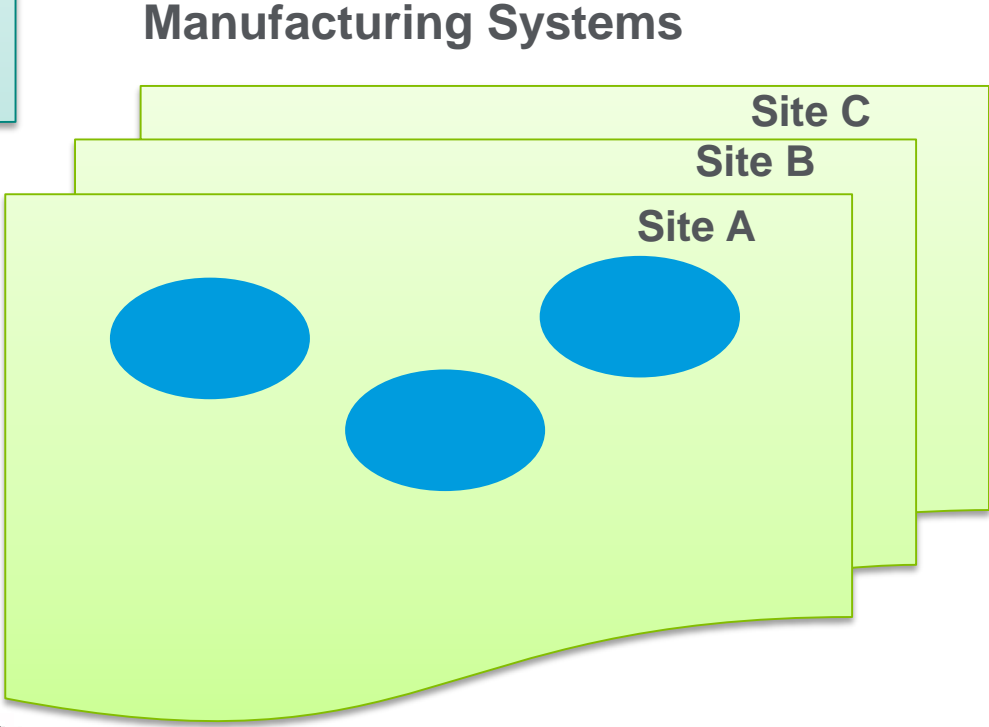
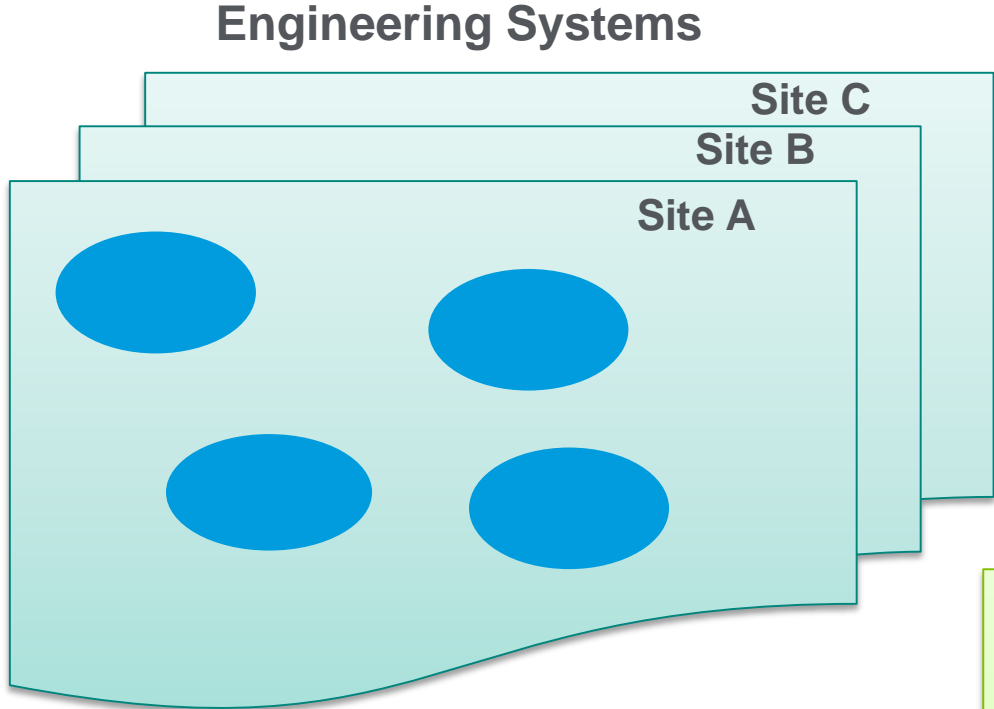

Leverage the PLM Platform for Consolidation and Integration of Baselines

Design History Baseline – Example - DHF (Minerva/Aras Solution)

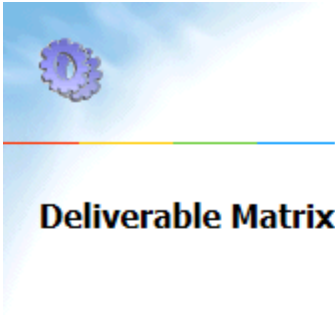

Deliverable Matrix

Number
DM-00206

State
Start

Name
8617 - Quality Center Upgrade

Description

DMR Toc Category Template
[PDX DMR](#)



















Product
[8617 - Quality Center Upgrade](#)

Active Phase

DHF Toc Category Template
[PDX DHF](#)

Subsystem/Subsystem Version
[Default/Default](#)

Deliverable Matrix Line Actions

Actions ▾ | Pick Related ▾ |            Hide Search Criteria ▾ | Page Size:        

Name	Responsible	Number	Rev	State	Description	Phase	Health Status	Has Action	Notes [Press F2]
PDX Project Charter	Project Manager	AD5746	A	Preliminary		Phase 0	On Track	<input type="checkbox"/>	
PDX ARB0 Approval	IT Tech Lead	AD5747	A	Preliminary		Phase 0	On Track	<input type="checkbox"/>	
Computer System Validation Decision (OVD)	IT Tech Lead	AD5748	A	Preliminary		Phase 0	On Track	<input type="checkbox"/>	
PDX Gate Summary Report	Project Manager	AD5749	A	Preliminary		Phase 0	On Track	<input type="checkbox"/>	
PDX Project Communication Plan	Project Manager	AD5750	A	Preliminary		Phase 1	On Track	<input type="checkbox"/>	
PDX Legacy Retirement Plan	IT Tech Lead	AD5751	A	Preliminary		Phase 1	On Track	<input type="checkbox"/>	
Business Process Impact	Business Project ...	AD5752	A	Preliminary		Phase 1	On Track	<input type="checkbox"/>	
Organizational Impact Assessment	Business Project ...	AD5753	A	Preliminary	Organization Imp...	Phase 1	On Track	<input type="checkbox"/>	
User Training Plan	Business Project ...	AD5754	A	Preliminary		Phase 1	On Track	<input type="checkbox"/>	
Business Impact Analysis	Business Project ...	AD5755	A	Preliminary		Phase 1	On Track	<input type="checkbox"/>	
Procedures and Work Instructions	Business Project ...	AD5756	A	Preliminary		Phase 1	On Track	<input type="checkbox"/>	
PDX Data Privacy Checklist	IT Tech Lead	AD5757	A	Preliminary		Phase 1	On Track	<input type="checkbox"/>	
PDX SOX-SOD Checklist	SOX/SOD	AD5758	A	Preliminary		Phase 1	On Track	<input type="checkbox"/>	
PDX IT Security Assessment	IT Tech Lead	AD5759	A	Preliminary		Phase 1	On Track	<input type="checkbox"/>	
PDX Application Design Plan	IT Tech Lead	AD5760	A	Preliminary		Phase 1	On Track	<input type="checkbox"/>	
PDX IT Security Gap Closure Plan	IT Tech Lead	AD5761	A	Preliminary		Phase 1	On Track	<input type="checkbox"/>	
PDX Business Requirements	Business Project ...	AD5762	A	Preliminary		Phase 1	On Track	<input type="checkbox"/>	
PDX Data Design Plan	IT Tech Lead	AD5763	A	Preliminary		Phase 1	On Track	<input type="checkbox"/>	

Define a Common Change Control Process in PLM

ECN Main
Affected Items
Supporting Items
Attachments
Originating Events
RoHS Risks
SignOffs

Supporting Items
Add
Remove

ECN Main

ECN Number: _____

State: _____

Originated By: _____

Release Date: _____

Assign To: _____

Is Fast Track

Change Code (Choose All That Apply)

- Documentary/ Drawing/ BOM Issue
- Manufacturability/ Obsolescence
- Cost Reduction/ Enhancement
- Functionality/ Reliability
- New Product/ Extension
- Regulatory/ Safety Requirement
- Serviceability
- UDI Relevant

Created By: _____

Created On: _____

Modified By: _____

Modified On: _____

Locked By: _____

Originating Product: _____

Subsystem / Subsystem Version: _____

Change Category: _____

Applicable Reference Documents: _____

User Manuals Affected: _____

Service Documents Affected: _____

Manufacturing/Production Documents Affected: _____

Risk Management Impact/Justification: Yes No N/A

Process Verification Required/Justification: Yes No N/A

Design Verification Required/Justification: Yes No N/A

Product Safety Impact/Justification: Yes No N/A

EHS/ECC Impact/Justification: Yes No N/A

Overall Description of Change:

Business Case:

This field is no longer required

Remarks:

Process Validation Required/Justification: Yes No N/A

Design Validation Required/Justification: Yes No N/A

EMC Impact/Justification: Yes No N/A

Regulatory Filings Affected/Justification: Yes No N/A

Configured
PLM Solution in
ARAS Innovator

Approvers	Addressed By	Originated By	Notifications	Hide Search Criteria	Page Size:		
_____	_____	_____	_____	_____	_____	_____	_____
Team Role [Press F2]	Primary Member [...]	Sequence Order	Can Remove	Sign-off Required	Reason of Signoff NOT Required	Modified By [Pres...]	Modified On [Pres...]

Impact of the IoT and Machine Connectivity

...more frequent and faster product software updates to harness market opportunities

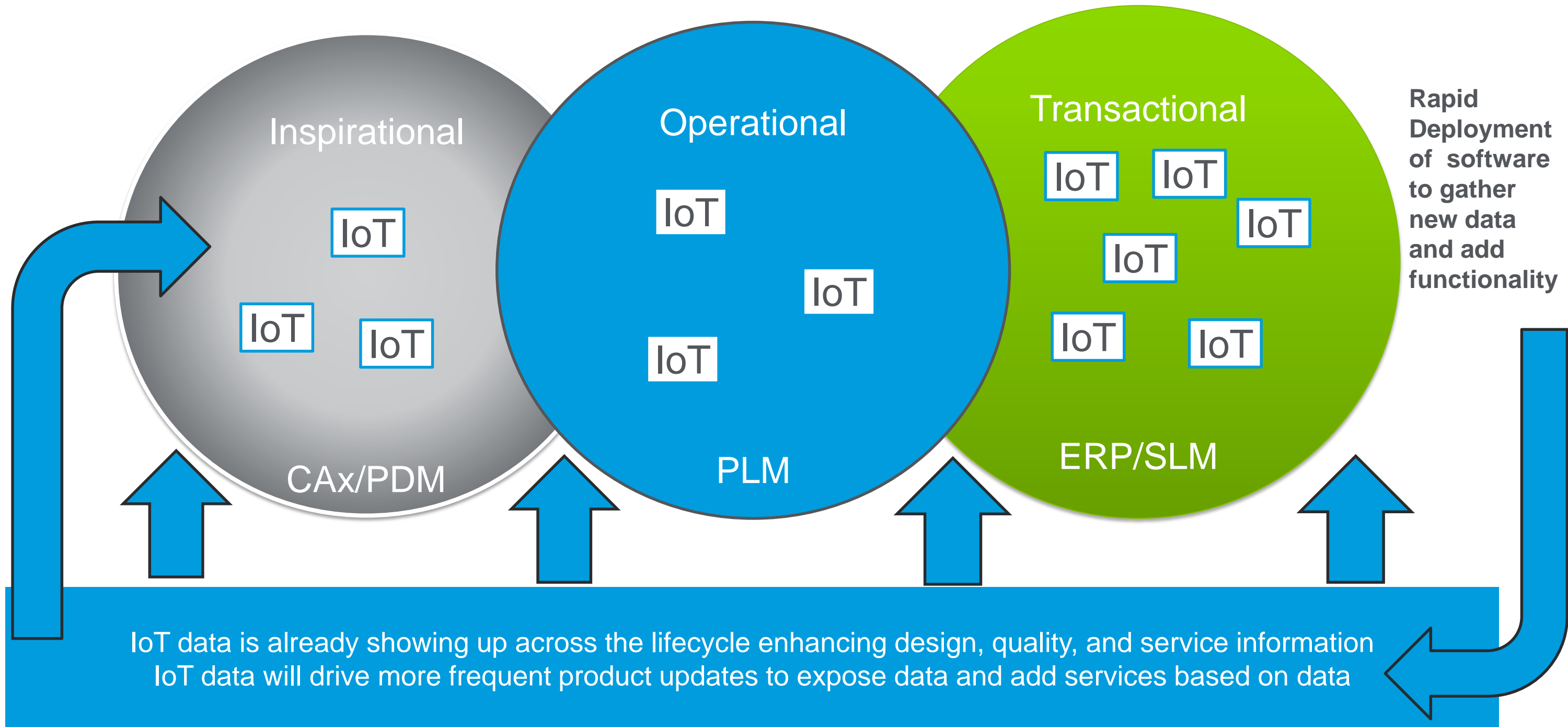

Critical Take a ways

REALIZE IT – 3 IT Technology waves have already drastically changed the working environment and are combining to bring about exponential change in markets. IT is becoming a strategic function.

HARMONIZE IT – So that you have the focus to be successful and remain compliant and efficient in the data enabled IoT world

LEAD IT– provide a solid IT strategy that aligns with business vision and work together with the business and functions on solutions to business problems

INTEGRATE IT- across functional teams form an Integrated Lifecycle Management (ILM) Ecosystem consisting of QMS, PLM, ALM,PDM, ERP, SLM....

Enterprise PLM is a CORE Platform - Product Lifecycle Management enables automation and is core to controlling all PRODUCT related configuration items through automated processes

- Define – critical baselines (DHF,DMR) and configuration items clearly
- Consolidate- product records into a single PLM system
- Create Information Flow - enable “Hyper Innovation” cycles with fast and efficient “lean” automated business processes

Join me in conversation!

CIOReview

Is PLM Ready For The Future?

By David G. Sherburne, Director of IT, Carestream Health Inc

CIOReview >> PLM >>

News | **CXO Insight** | Vendors

CUT VERSION-Is Technology Still the Main Road to the Customer?

By David G. Sherburne, Director of IT, Carestream Health

David G. Sherburne

Executive IT Director- Carestream Health Incorporated
Technology Consultant and Evangelist
Avid Photographer

me@davidgsherburne.com

<https://www.linkedin.com/in/davidsherburne>

www.queptography.com

<https://www.twitter.com/dgsherburne>

david.g.sherburne@carestream.com

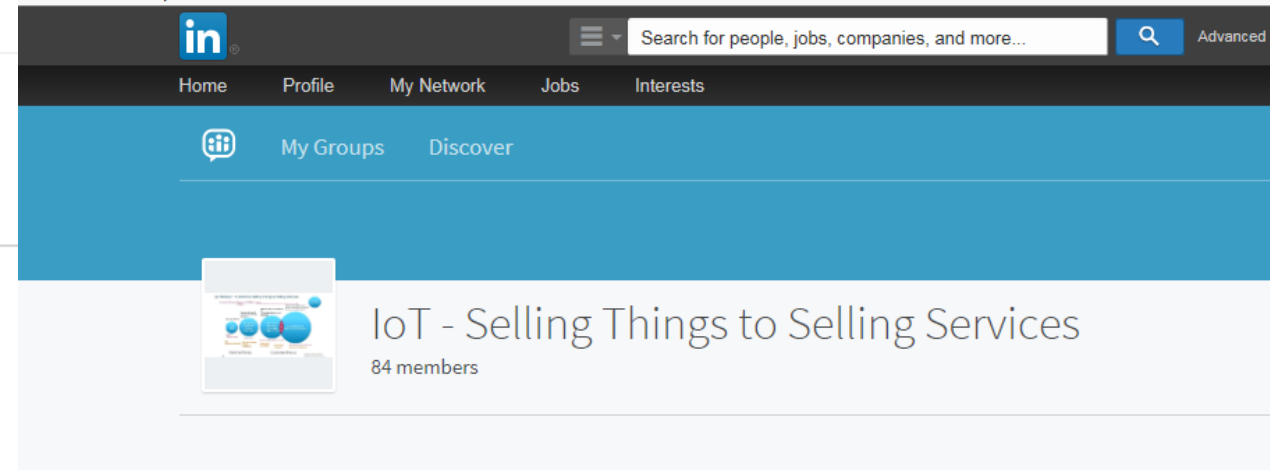

IoT RESULT – A Shift from Selling Things to Selling Services

Increasing Business Process and Selling Process Changes

Revenue Opportunity

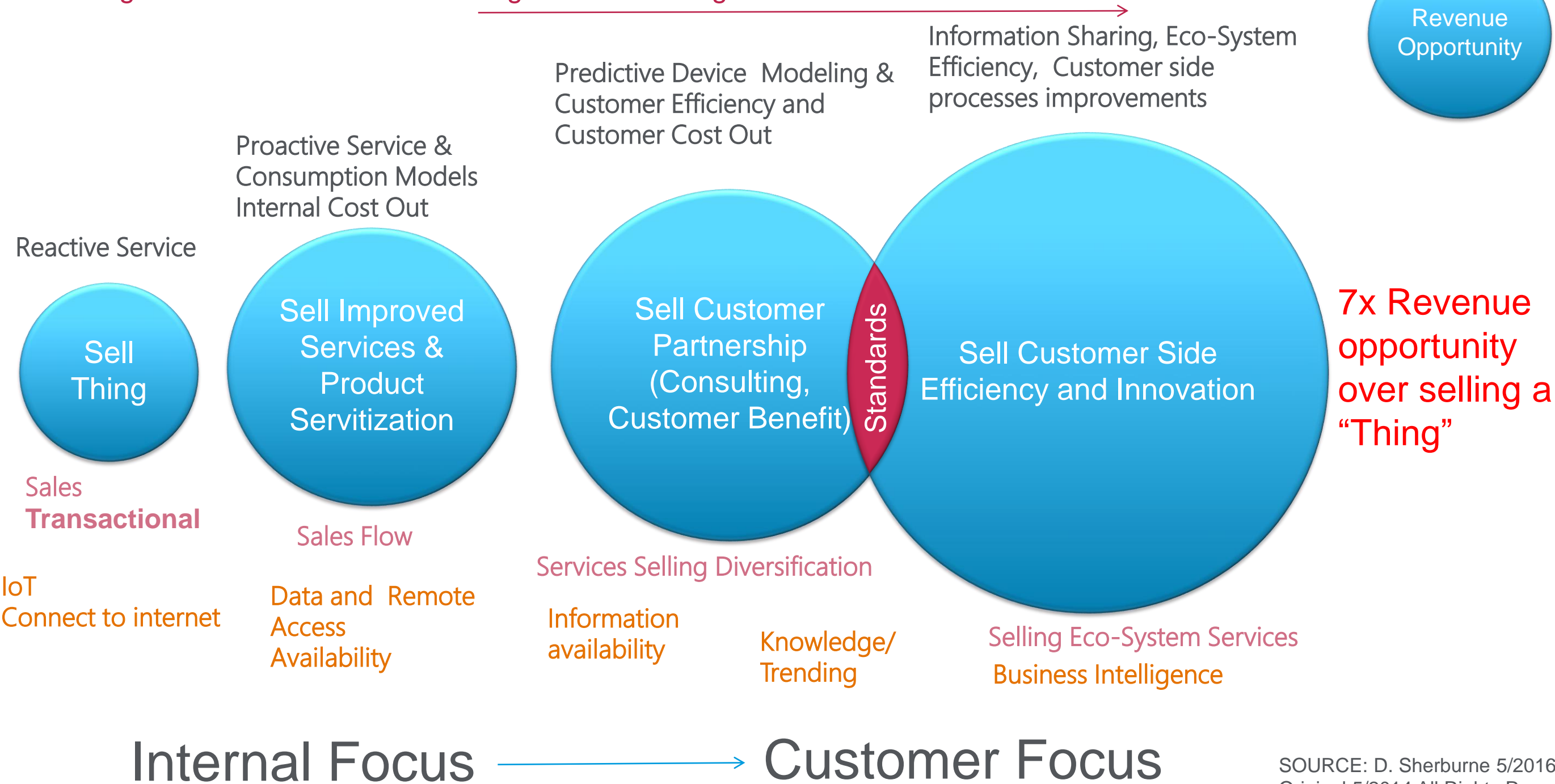

SOURCE: D. Sherburne 5/2016
Original 5/2014 All Rights Reserved